

10X18cm

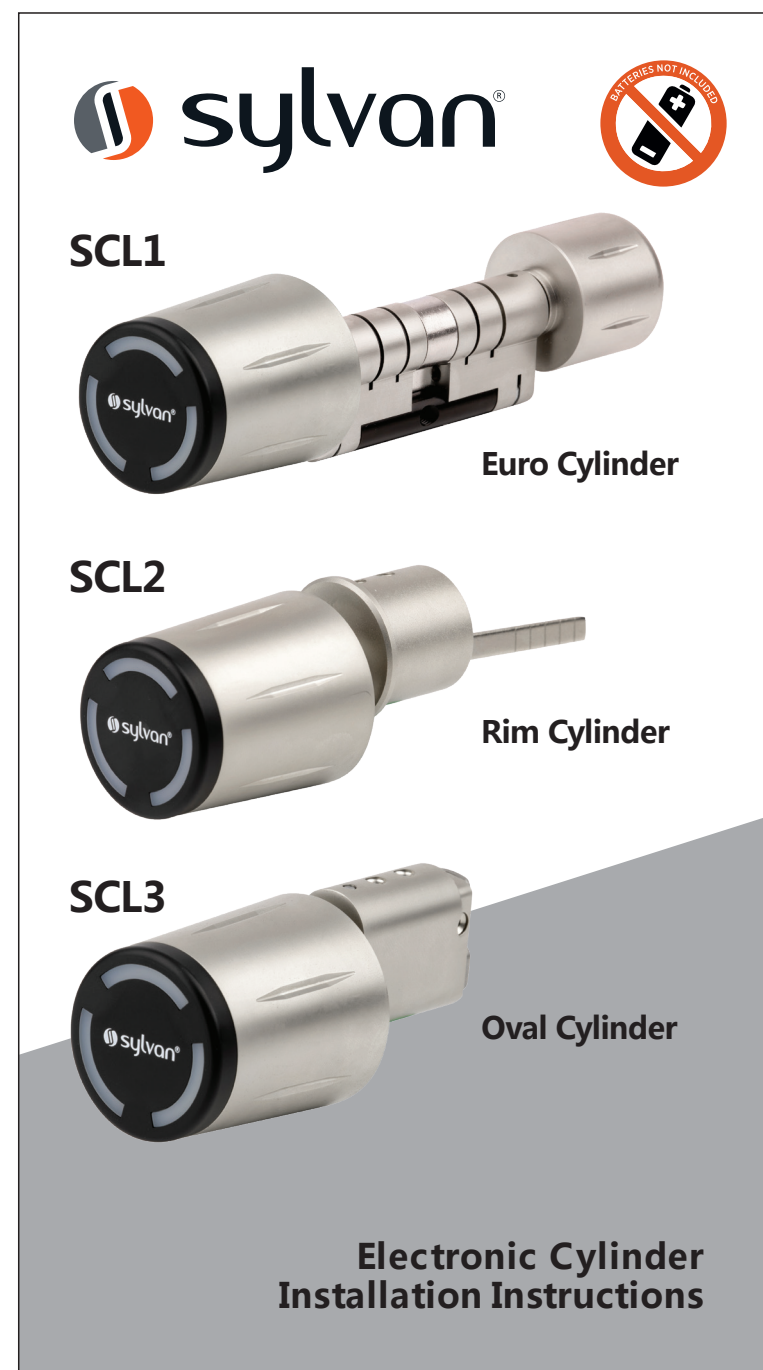

5B01 Electronic Cylinder (TTLOCK APP)

Test standard > En15684

1 6 0 4 A F 0 2

What's included

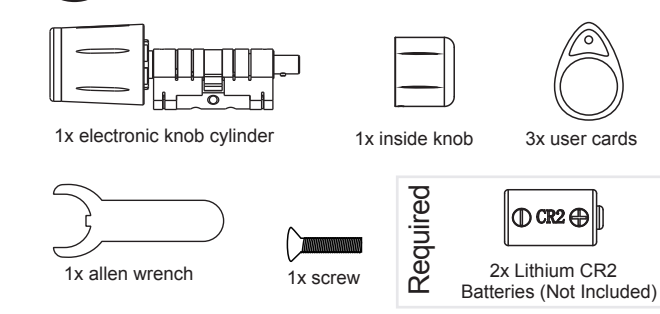

Installation instructions

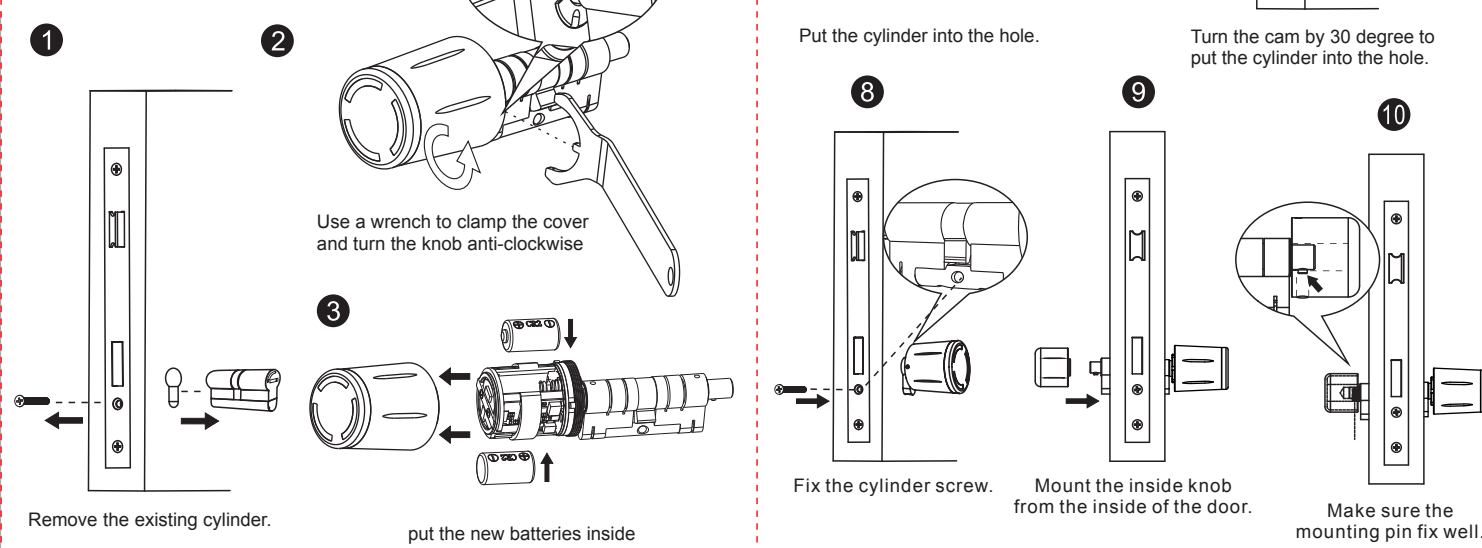

Use a wrench to clamp the cover and turn the knob clockwise

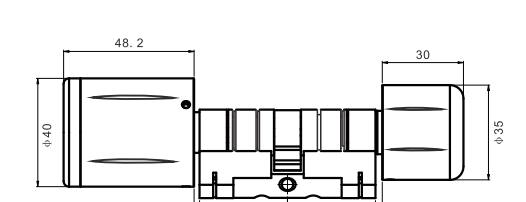
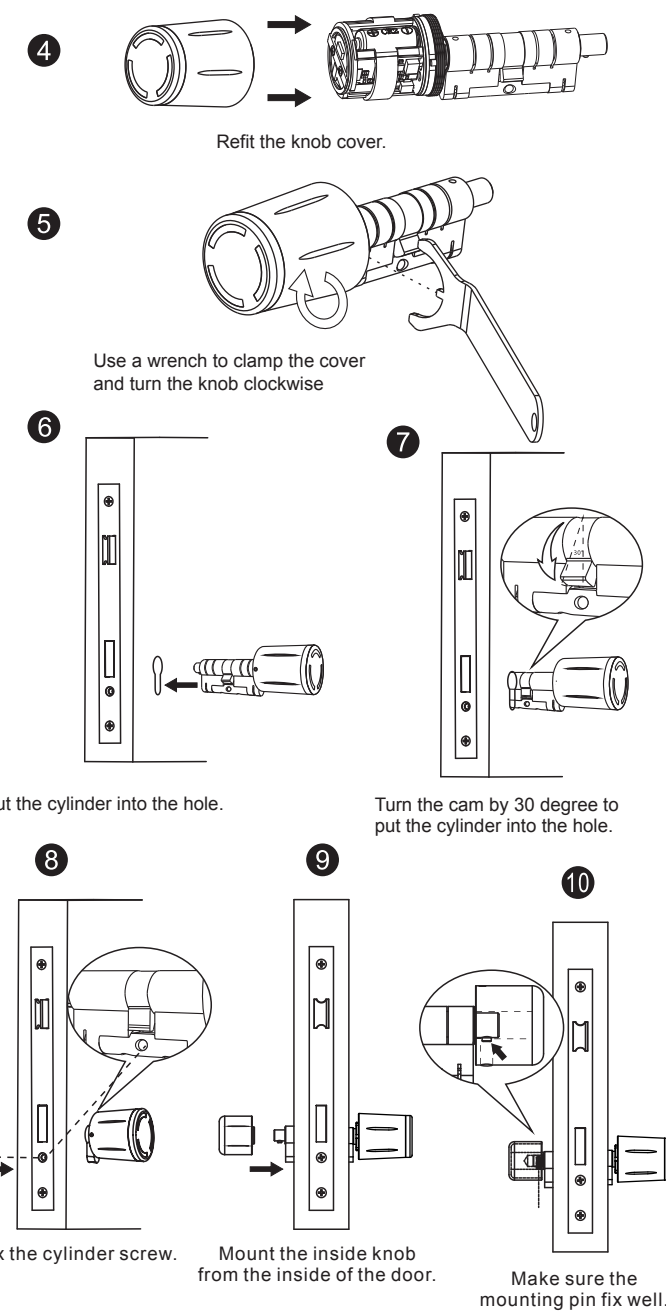

Cylinder length

- Basic length 32.5/32.5 mm (Euro profile)
- Fits into doors with thickness from 35mm to 45mm

What should pay attention to

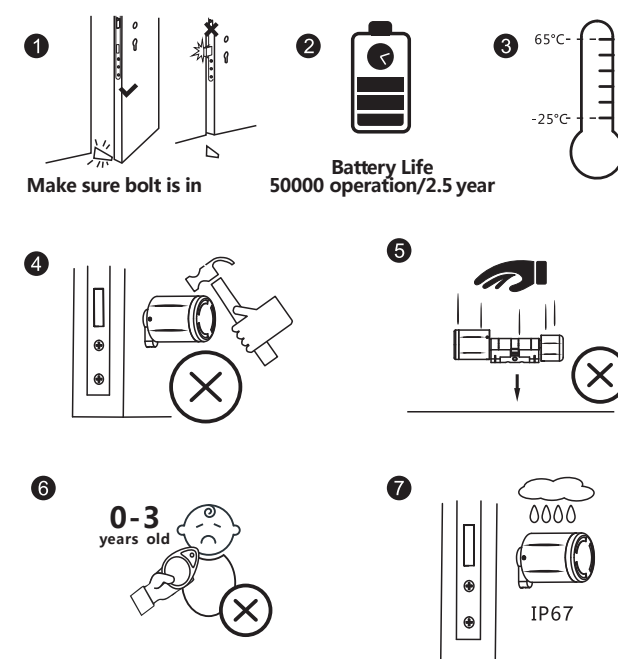

Functional features

Function	Explain
Encrypted communication	Encrypted communication is carried among lock-app-server.
Door opening records	Unlocking method + unlocking IC + time. Users can get the door opening records in recent 6 months through the app. No data lost.
Cache	The electronic cylinder can cache each door opening record locally. The data will be automatically synchronized to the app when the app is connected with the cylinder via Bluetooth.
Alarm	Low battery alarm, door opening alarm.
Manage users	Adding new users by app.
Power status display	Power value or status
Door opening via app	After bluetooth connection is established between the mobile phone and the cylinder, you can open the door directly via the app.
New user cards added via app	After connection is established between the mobile phone and the cylinder via bluetooth, you can add new user cards via app.
share in a specified validity period	Administrators can create a user with a specified validity period via the app.
Door opening mode synchronization	After direct connection with the app, the door opening methods synchronize between the cylinder and cloud.

How to use

Please read the manual carefully before installation and keep this manual at a secure place.

1. For the installation and debugging not recorded in the user's installation manual, please consult the purchased distributor store or installation master.
2. Please bind the APP administrator account before using the lock.

Download the APP



Scan the QR code to download and install the APP

The iOS version can be downloaded from the app store, and the Android version can be Downloaded from Google play

1. Registration and Login

Users can register their accounts with their mobile phone numbers and email addresses. Currently, mobile phone numbers in more than 200 countries and regions are supported. During registration, a verification code will be sent to the entered mobile phone number or email address. After the verification passes, the registration succeeds

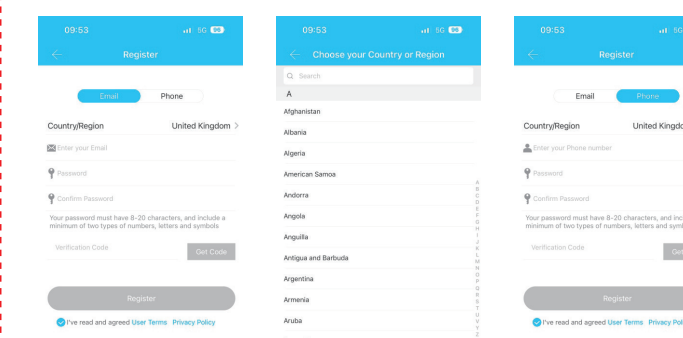

2. Adding a lock

Adding a Bluetooth Lock

TTLock App supports a variety of lock devices, including door locks, padlocks, safe lock, smart lock, parking space lock, bicycle lock remote control device

1. The "Add Lock" menu is displayed in the upper left corner of the interface
2. Select all locks, eject nearby locks, and add locks
3. The lock name with a black "*" indicates that the lock can be added
4. The door lock name with a grey "*" indicates that the door lock cannot be added

Note: Please use your IC card to wake up Bluetooth before searching and adding, and ensure that Bluetooth is turned on. The status can only be added. If the binding fails, repeat operations

3. Supporting Bluetooth gateway (to be purchased separately)

1. Power up the gateway. Please turn on Bluetooth of your mobile phone and connects to 2.4G WiFi (pls note that if the router supports both 2.4G and 5g modes, the mobile phone must be connected to the 2.4G network and does not support 2.4G and 5g mixed modes).
2. After the gateway is powered on, pls check if the distributor network indicator blue light is on. If not, press and hold the reset button near the power socket until the blue light is on (as shown in figures 1 and 2).

Overview of lock functions

Interface Introduction

- APP menu bar (Add lock, gateway, transfer lock, set language and other operations)
- Lock name, lock status and lock power
- APP unlock key, remote unlock and other operations
- Door lock management (electronic key, password, card fingerprint, etc.)
- Lock function Settings (authorizing administrators, checking operation record lock Settings, etc.)

If your smart lock does not support a function in the APP interface, the function will not be displayed on the west of the APP interface.

1. Electronic key

Sending electronic keys

The sending key here refers to the sending Bluetooth key. The administrator has the right to send the key. The sending limit can be set as required. For four types of keys, namely, time, permanent, single time and cycle keys, remote unlocking and real name authentication can be checked when sending electronic keys. If the recipient's account is not created, it will automatically generate an account and notify the other party by SMS.

Electronic Key Management

The administrator can manage all keys issued by the administrator, including resetting keys, sending keys, changing the validity period of keys, and viewing key operation records. The key can be frozen or upgraded to an administrator key.

Electronic key expiration reminder

For the key that is about to expire (non-administrator user), the lock user is about to expire (yellow indicates the remaining days) and expiration reminder (red font).

2. Cards

Add Delete reset

1. Supports various IC cards to open doors. Before an IC card is used to open, it needs to be added first. The adding process takes place next to the lock via the App. The expiry date of the IC can be set, either permanently or for a limited time. After setting, you can also modify its validity period. To delete, the IC card can also reset the lock IC card.
2. With the gateway, you can use the lock management platform to issue the card number, or you can use the hotel to write the card to issue the card. For details, see the instructions.

Add Delete reset

IC card details can check, modify the validity period, view operation records and delete operations.

3. Authorizing an Administrator

Select the door lock and click Authorize Administrator to enter the administrator management interface. You can authorize other administrators on this interface. Authorized administrators are classified into permanent authorization and limited time authorization. If you select an administrator, you can freeze, disauthorize, and delete an administrator. Deleting an administrator. You can choose whether to delete the permission delivered by the administrator.

4. Operation record

Click Operation record in the lock management interface to view the unlock record of electronic key, password, card, fingerprint, face, remote key, QR code, etc. If the unlock record is not uploaded, you can click read the record to update it.

5. Lock Settings

Basic Information

D Basic information: you can check the lock number, MAC/D, power, expiration date, check or modify the lock name and group, and check the administrator to open the lock.

Remote unlocking

When enabled, you will be able to unlock the lock remotely through the gateway. This function can only be turned on and off through the Bluetooth of the mobile phone near the unlock.

Automatic closing

After the time set above, the lock will brake to close. After enabling or modifying, open the lock for the time to take effect.

Normally open mode

1. During the normally open time set, the lock will remain open until it is manually closed.
2. The normally open mode can be turned on or off. You can set the normally open time to a specified period or all day from Monday to Sunday.

4. Set up

4.1 Unbind APP (delete lock)

1. Select the account to be deleted
2. Enter the menu and click "Settings"
3. Click the delete button
4. Enter the account password to delete it

4.2 Logging Out of an Account

On the outgoing menu at the upper left corner of the interface, click "Set" and select "Outgoing Account" to delete the current account. After deleting the expansion number, all your information and related records will be deleted from the bottom of the platform and cannot be recovered.

4.3 Deleting an Account

In the outgoing menu interface at the upper left corner of the interface, click "Set" and select "Outgoing Account" to delete the current account. After deleting the expansion number, all your information and related records will be deleted from the bottom of the platform and cannot be recovered.

GDRutter

127 Diana Drive
Glenfield
Auckland 0627
Ph: +64 9 444 5359
Email: sales@gdrutter.co.nz
Web: www.sylvan.co.nz