

1 Mark and drill door.

Using template, mark

- Centre of door edge
- 6mm holes x2
- 4mm hole x2
- 20mm hole through door.

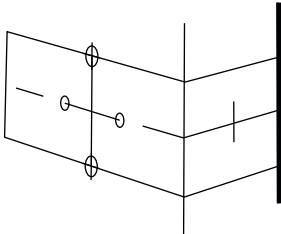

- Drill 25mm hole square to door edge, 100mm deep
- Drill 20mm hole through door face from both sides
- Drill 2x 6mm holes through door face from both sides
- Drill 2x 4mm holes through door face from both sides

2 Check forend of latch and fit latch

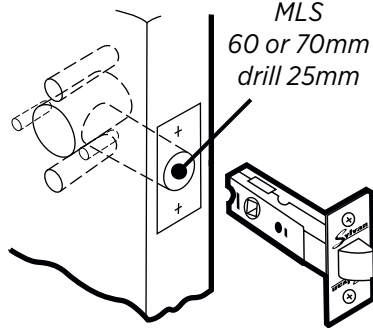

3 Fit spindle through latch

Offset hole at the bottom, Allow equal length of spindle on either side of door

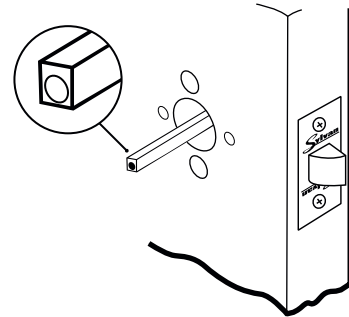

4 IMPORTANT STEP

Fit through bolt fixing screws

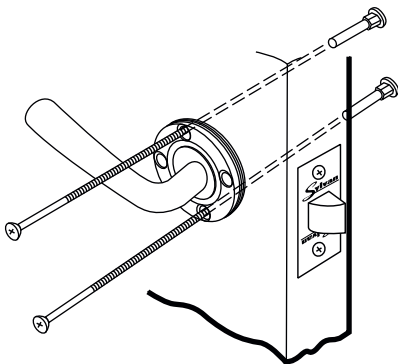

5 Drill and fit 4 wood screws for alignment only

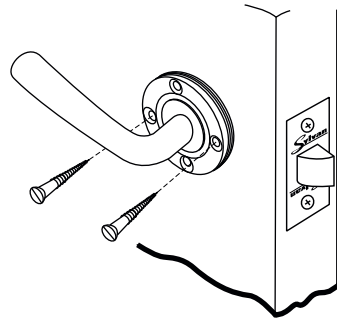

6 Fit cover plates over handles

Tighten up grub screws onto the spindle using allen key provided

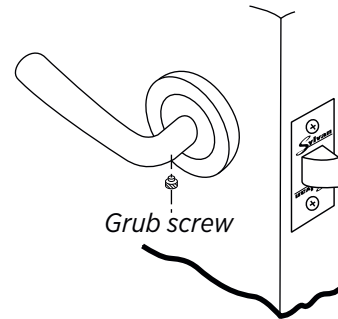

Square door edge Bevel door edge

Place template on high edge of bevel door

Mark centre of door

Drill 25mm hole at centre of the door edge

