



SL43E

INSTALLATION INSTRUCTIONS



Version 6

Introduction

Thank you for choosing Sylvan, this lock is for Residential use only, and its two year warranty (mechanical and electronic) only applies for locks being used for residential use.

To ensure you get the best out of your purchase we ask that you follow the below:

- Please read these instructions fully before installation of this lock.
- We recommend this lock is installed by a professional installer or a serious DIYer to ensure correct installation and operation.
- The supplied rubber boots must be installed; however, this smart lock requires a smooth flat surface to hold its water tightness. This lock is not suitable for use on a tongue and groove door, where water can penetrate the lock via a groove in the door.
- We recommend that this lock is never fully exposed to direct weather for long periods of time. For long lasting properties of the product, positioning the lock under a eave or sheltered position is best.
- This lock is rated IP55, but only on the outward face of the lock. No warranty is given if the lock gets damaged from water for the inside of the door.
- This lock is not suitable for use on a gate.
- This lock comes with a mechanical key override, this can be used in a situation of complete battery loss. We recommend an override key is put somewhere safe outside in case complete power loss.
- Replace batteries when they are showing low voltage on the app.
- All batteries used with this lock must be high quality Alkaline (4 x AA batteries), to ensure long lasting use. We recommend Energizer Max Alkaline Plus Batteries.
- Rechargeable batteries cannot be used with this lock.



Installation Video

Scan this code:



App Setup Video

Scan this code:







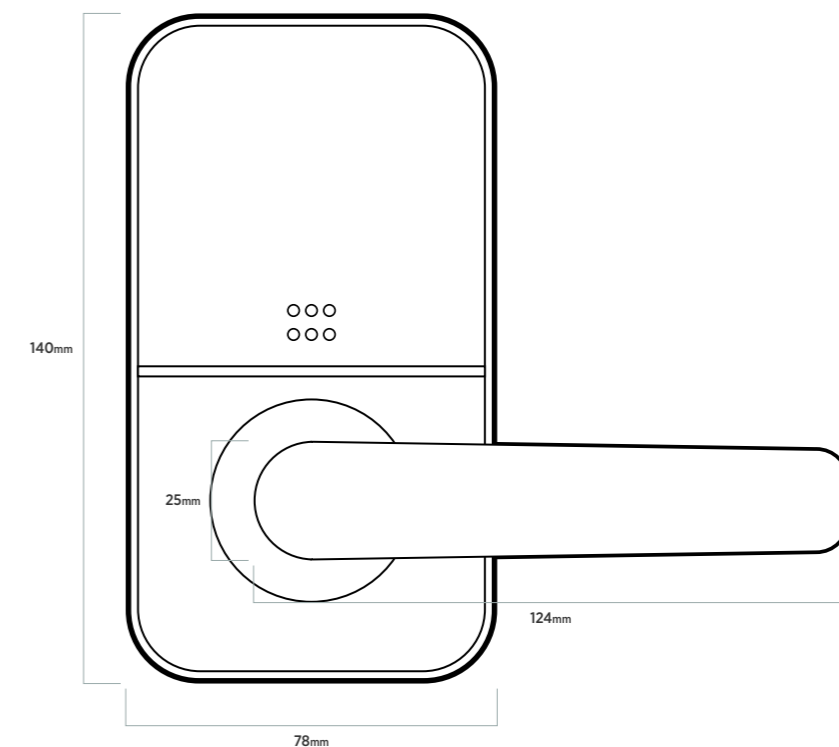
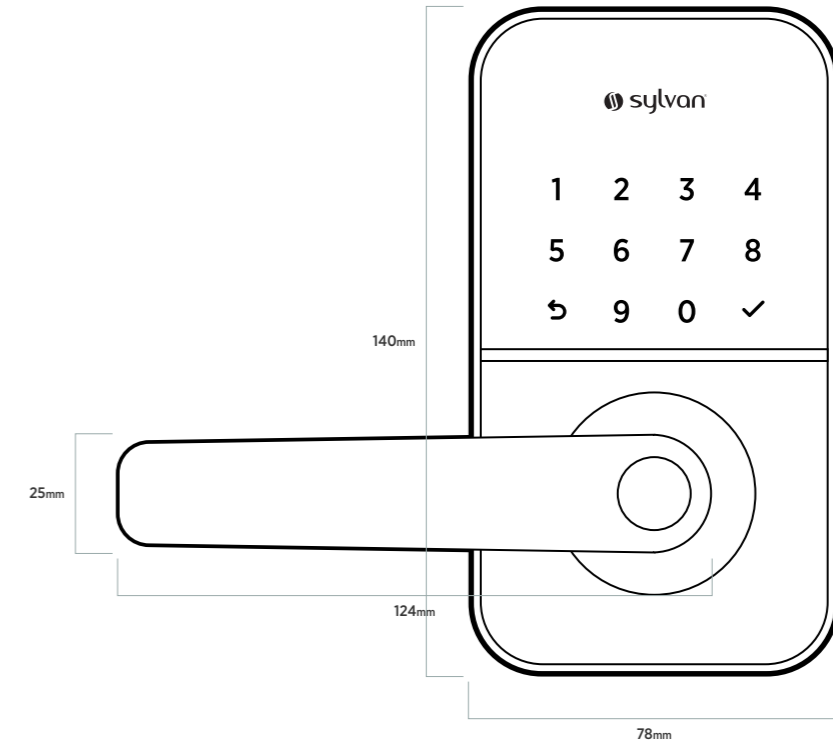





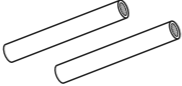
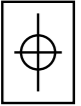

We recommend Energizer Max Plus AA x4

Lock Dimensions

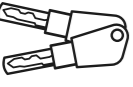
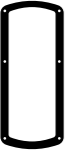
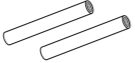
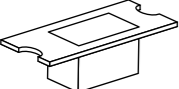

SL43E Packing List

- | | | | |
|---|--|---|---------------------------------------|
|  | • Front panel
Qty x1 |  | • Pin x1 - for resetting |
|  | • Back panel
Qty x1 |  | • Positioning Collumns (A) x2
35mm |
|  | • User manual
Qty x1 |  | • Screw (B) x4 |
|  | • Installation template
Qty x1 |  | • Allen Key x1 |
|  | • Mortice lock / latch
Qty x1 |  | • Screw (G) x3
65mm |
|  | • Striker plate
Qty x1 |  | • Screw (F) x3
45mm |
|  | • RFID Tag
Qty x2 |  | • Spindle (B) 60mm |
|  | • Self adhesive disc
Qty x2 |  | • Spindle (C) 75mm |
|  | • Mechanical keys
Qty x 2 |  | • Screw Stub (E) x3
35mm |
|  | • Waterproof rubber boot
Qty x2 - Inner & Outer |  | • Screw Stub (D) x3
30mm |
|  | • Striker
Plate Box
Qty x1 |  | • Smart hub
Qty x1 (optional) |
| | |  | • Adhesive plastic plugs (H) x3 |

Product specifications:

Model number	SL43E	Door thickness range	35mm - 65mm
Material of Manufacture	Aluminum alloy	Low voltage Alarm	Less than 4.8 Volts
Weight	2 kg	Type of use	Residential use only
Options of unlocking	Bluetooth Password Card Mechanical key Gateway(option)	Passcode capacity	App unlocks Passcodes: 150 max RFID Cards: 200 max
Working temperature	-10 – + 55 degrees C	Working Humidity	0-95%
Normal voltage	6 volts (4 x Alkaline batteries)	Warranty	2 years mechanical 2 years electronic

Anti Peeping Technology

This lock offers anti-peeping virtual passcode entry by inputting a random passcode either before or after the proper passcode followed by the # key.



Installation:

Notice: Adjust the handle according to the direction you open the door. The door opens to the left, with the handle facing left. The door opens to the right, with the handle facing right.

For Exterior Assembly:



1. Loosen the screw



2. Adjust the direction of the handle



3. Tighten the screw

For Interior Assembly:



1. Loosen the screw



2. Adjust the direction of the handle

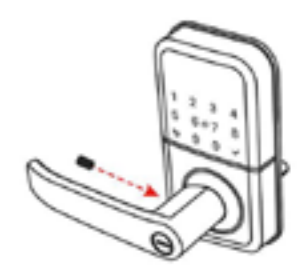

3. Tighten the screw

Step 1: Install Latch

1. Mark and crop door using installation template provided
2. Ensure holes are clear of any sharp edges and clean of swarf and wood dust.
3. Install the latch into the door with screws

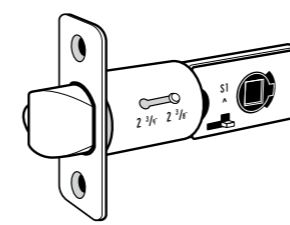
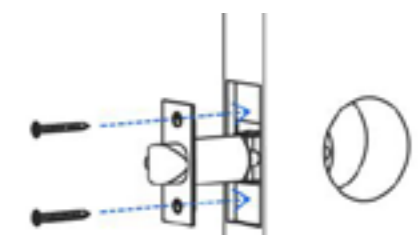

1

CHECK LATCH LENGTH
Determine if latch is the correct backset for the door. If incorrect, you can adjust to 60 or 70mm backsets.

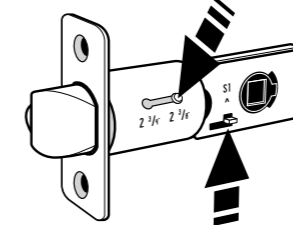

2

DEPRESS BUTTONS
To change the latch length of backset simultaneously press the (S1) button upwards and the length button in.

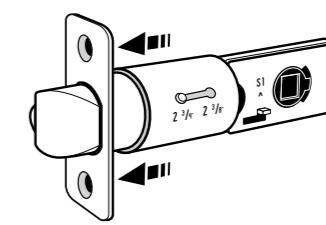

3

EXTEND LATCH
With both buttons pressed, pull on the latch forend until it reaches the desired length

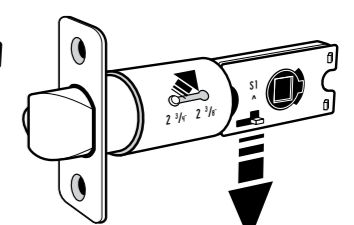

4

RELEASE BUTTONS
When the lock is adjusted to the desired length, release both buttons and check lock function. The lock is now set to 70mm backset

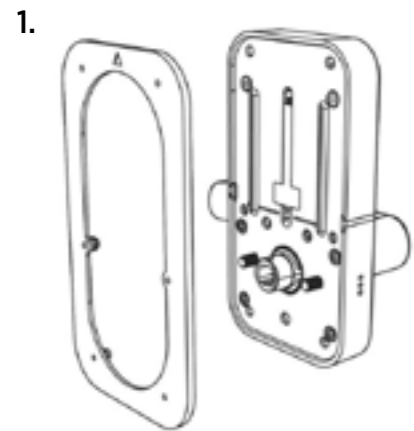

Step 2: Install Exterior Assembly

1. Attach the Rubber Plate: Place the waterproof rubber plate on the exterior assembly, making sure it fits flat and into the correct holes.

2. Choose the Spindle Length:

For doors 35mm – 48mm thick, use the 60mm spindle (B).

For doors 48mm – 65mm thick, use the 75mm spindle (C).

Ensure the spindle clips securely into the assembly. fig2.

3. Screw in Positioning Columns: Attach the two positioning columns (A) on each side of the spindle, tightening them well.

4. Install Screw Stubs:

For doors 35mm – 48mm thick, use 30mm stubs (D).

For doors 48mm – 65mm thick, use 35mm stubs (E).

Tighten stubs with a crescent wrench.

5. Mount the Exterior Assembly: Align the exterior assembly over the latch in the door, ensuring the power cable is above the latch. Check that the spindle and positioning columns fit correctly.

Important: The spindle should not stick out more than 30mm from the door's inside face. If it does, switch to the shorter spindle.

Step 3: Install Interior Assembly

1. Attach the Rubber Plate: Secure the waterproof rubber plate to the interior assembly, ensuring it fits flat in the seal slot.

2. Connect the Power Cable: Plug the wire into the receiving socket, making sure it's oriented correctly.

Important: To remove the assembly, press the clip on the plug before pulling it out to avoid damage.

3. Secure the Exterior Assembly:

Use the appropriate screws:

For doors 35mm – 48mm thick, use 3 x F screws (45mm).

For doors 48mm – 65mm thick, use 3 x G screws (65mm).

Make sure the power cable isn't pinched against the door.

4. Cover the Screws: Once everything is in place, stick 3 self-adhesive buttons (H) over the fixing screws.

5. Install Batteries: Insert 4 high-quality AA alkaline batteries (we recommend Energizer Max for longer life).

6. Add the Battery Cover: Secure the battery cover.

7. Mark the Striker Plate Position: Locate and mark where the striker plate and box should go, centering them in the frame.

8. Chisel the Frame: Create space in the frame for the striker box and plate.

9. Adjust the Anti-Rattle Tongue: Ensure the latch fits properly into the striker plate when the door is closed. Making sure the guard bolt is correctly positioned.

10. Completion: The mechanical installation is now complete.

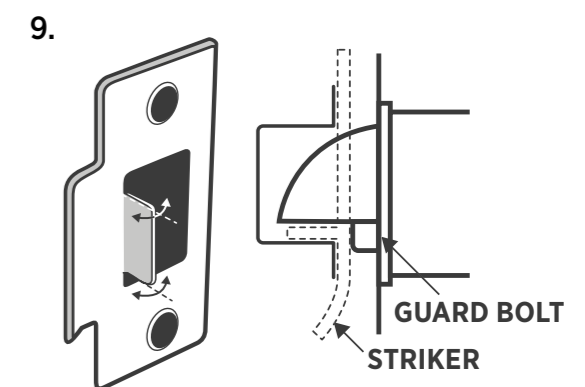
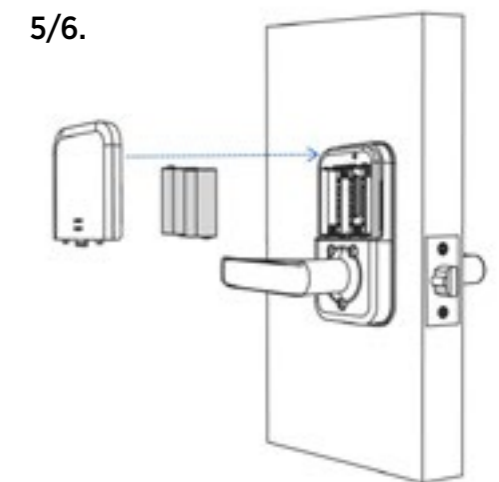
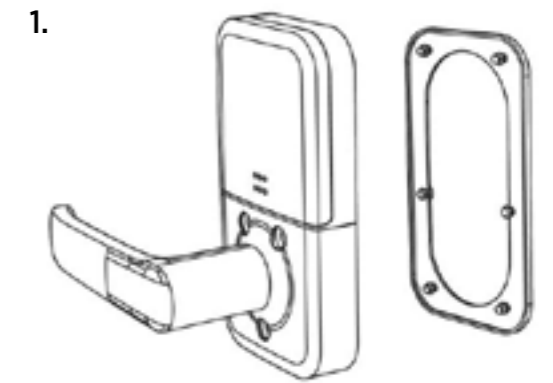
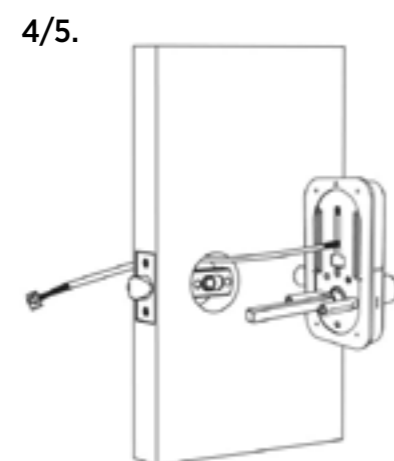
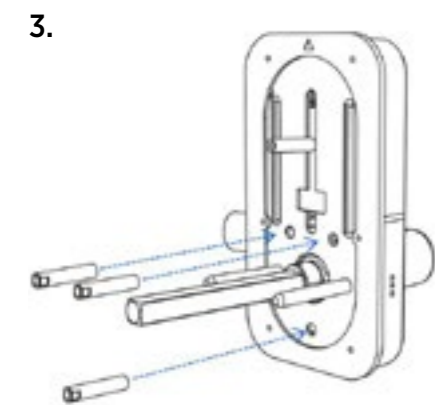
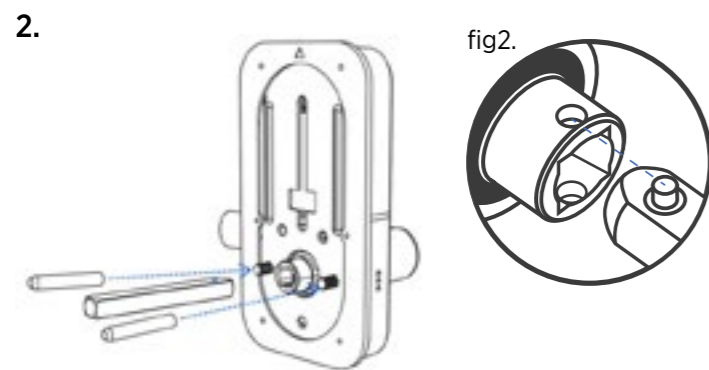

Lock Installation Checklist

1. Holes drilled and aligned as per drilling template.
2. Ensure the rubber boot is aligned correctly with a good seal on the door, also making sure the lugs are correctly seated in their holes .
3. Ensure all screws and bolts are correctly tightened.
4. Ensure power cable is installed and not bent or crimped in door.
5. Check batteries are Alkaline and installed correctly.
6. Check to see if the lock requires a software update via the TT App

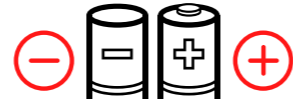

1. Date Installed: / /
2. Installed By: _____
3. Pin: # _____

Manual reset:

If you are not admin of the Smart Lock, remove battery cover and complete:

Long press the reset button beneath the battery case for 5 seconds or until you hear: "Please Input Initialisation Passcode".

Now input code "000✓" on the keypad.

The system reset will be complete. From here you can re-link the SL43E Smart Lock to your phone via the TT App.

**Note: this will clear all previous users from the locks memory*



Using your Sylvan SL43E Smart Lock

The SL43E Smart Lock has a mechanical key override to unlock it. The key location is on the front panel.

Insert one of the included keys, turn to unlock.

Maintenance Guide:

Maintenance should be carried out on your lock every 6 months:

- Check that the screws fixing the mortice Lock are tight. Check that the screws fixing the rear panel to the front panel are tight.
- Check if batteries need replacing. If battery percentage is low replace with four fresh Alkaline 1.5V AA batteries. We recommend Energizer Max Alkaline Batteries.
- Wipe the surface of the Lock with a damp cloth, we recommend only water is used. This will help remove any dust or micro contaminants from the surface.
- It is also recommended to do a full factory reset of the Smart Lock to ensure software runs correctly.
- Check rubber boot to ensure the seal between lock and door is still good.

TTLock App Set-up instructions:

1. Download app

- Download the TTlock app onto your device
- Through Apple (IOS version) use app store to download TTlock
- Through Android version go through Google play (English version)

Otherwise use the below QR codes

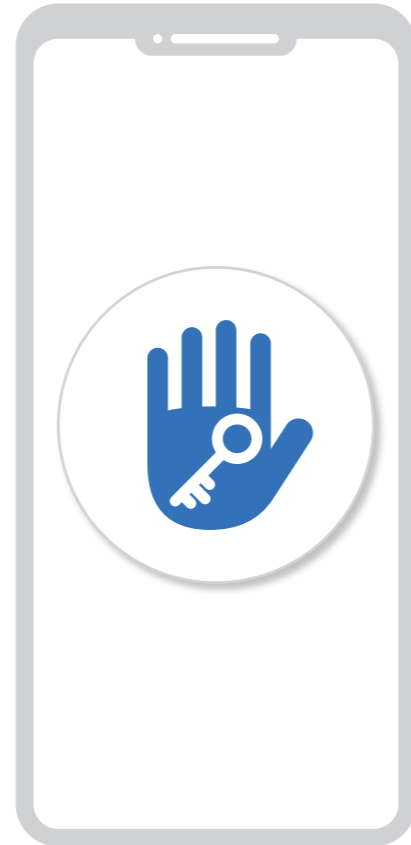
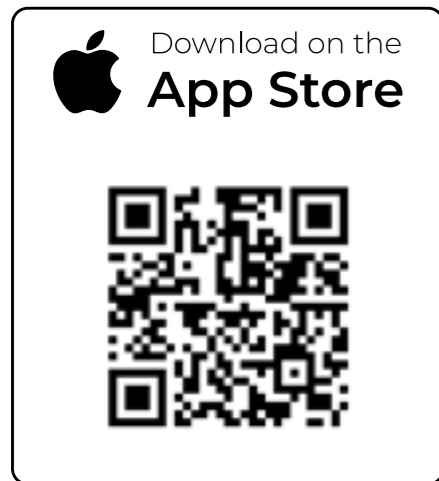

TTlock App

- TTlock supports multiple types of locks and devices
- TTlock currently supports 200 countries
- Verification codes will be sent to users' mobile phone or email depending on how you have registered above.

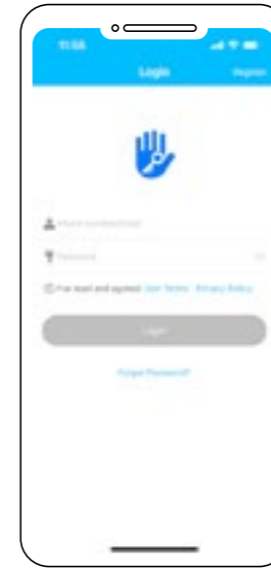

1. Register a new account (phone number or email) or login with an existing account if you already have one.



2. With App open touch on main screen + Add lock



3. While standing near the lock (and with the 4 good quality AA alkaline batteries installed into the lock) wake the lock up by touching the key pad.
4. Your lock will appear on the screen, then click +

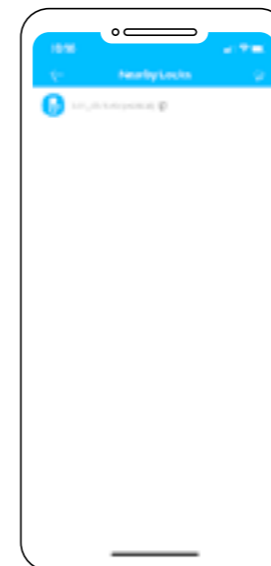

5. Rename the lock. e.g. home front door
6. The lock is now successfully added to the app.



7. If you have downloaded the app and loaded your lock on your device you are now the administrator of this lock, from here you can now add or delete users / passcodes / RFID card etc.

Management of app and lock

Bluetooth (lock and unlock)

- Make sure your phone has bluetooth is switched on your phone
- The app can be used to lock or unlock the door by using bluetooth within a 5m range.
- Note: the lock will automatically re lock itself depending on the setup of the auto lock function through the app.
- From the app push the (padlock) symbol to lock or unlock the device.
- Note: 5-meter Bluetooth range can vary depending on interference such as steel, thick walls and micro wave interference etc.

Setting a passcode:



- Passcodes are another way of unlocking the device
- This lock can accept up to 150 unique PIN codes.
- Careful consideration should be taken to ensure each PIN is set up in a way that they can be well managed at a later time. We suggest naming each PIN with the name of the person using it. E.g. Bobs PIN
- We suggest when setting up passcodes to do it via the custom setting to create your own pin number. It needs to be between 4-9 digits followed by '✓' e.g. 1234✓.
- Recurring PIN codes used to give access to the user of this code at certain time of day and week.
- You can also set up Pin codes for One timed and also timed access (for example a tradesperson working in your house for a short period of time).

RFID cards

- This lock comes with three RFID cards and can store up to 200 unique RFID cards.

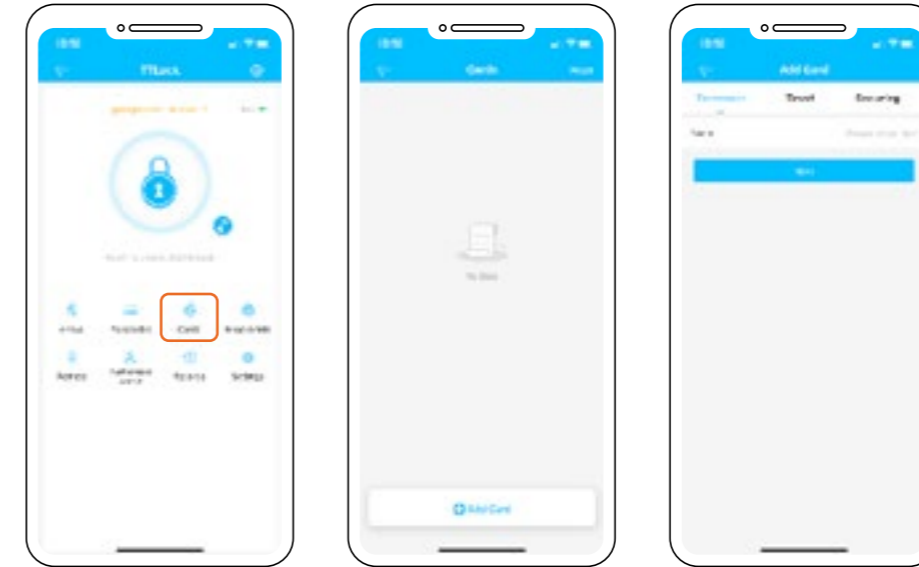

- To add these to the lock, touch RF Cards, then add card
- Decide if a Permanent or Timed or Recurring user
- Name the Card (we suggest the users name) e.g. Bobs RFID
- Then touch card against keypad to accept card to lock

Passage mode

- The TT app can be used to put the lock into passage mode. NB: Passage mode is where the lock can be opened without a passcode etc

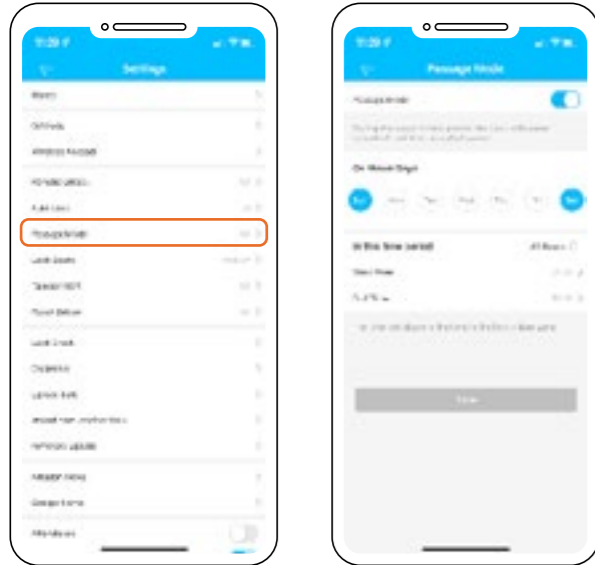

- Under the setting tab of the lock, you can switch passage mode on or off
- You can also set up a calendar so that the lock can go into passage mode on certain days at certain times.
- Note for security reasons the passage mode only starts once a successful entry to unlock the lock has been accepted.
- To lock the door when in passage mode, press and hold the ✓ key on the lock.**

Remote unlock

- This can be done using a smart hub SLG02 (sold separately) see 'sylvan.co.nz/smart-hub-slg02/'

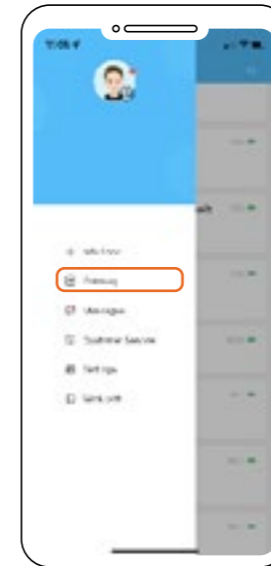

1. Add the smart hub via the first screen of the TTlock app



2. Click on add Gateway
3. Choose the G2 (Wi-Fi) option



4. Connect power to the gateway and the indicator light will flash red, it's now in programming mode



5. Click next
6. Once seen it will ask for you to name the gateway e.g. (garage door gate way)

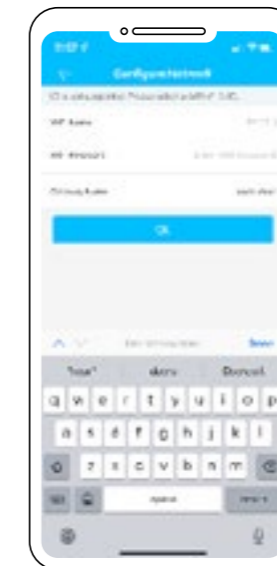

7. It will also ask for your Wi-Fi password (Note this needs to be a 2.4G signal. 5G is not supported)
8. Then the gateway is connected.



9. Check that the gateway is online under the gateway link off the front page
10. Ensure the gate way is within 10 meters of the lock

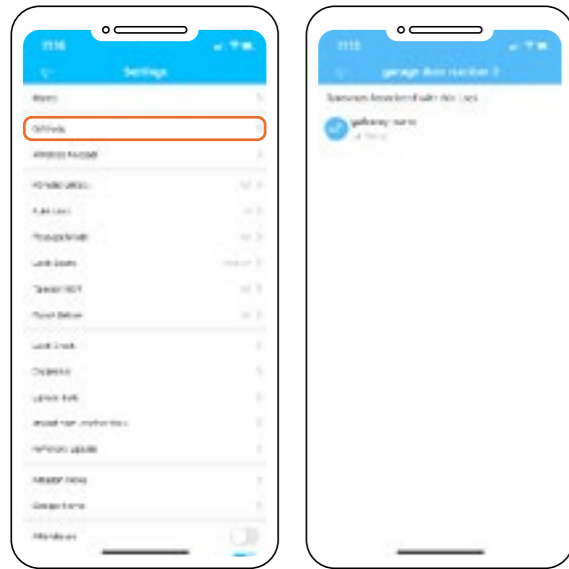

11. In the setting screen of the lock click on gateway and you should see your named gateway.

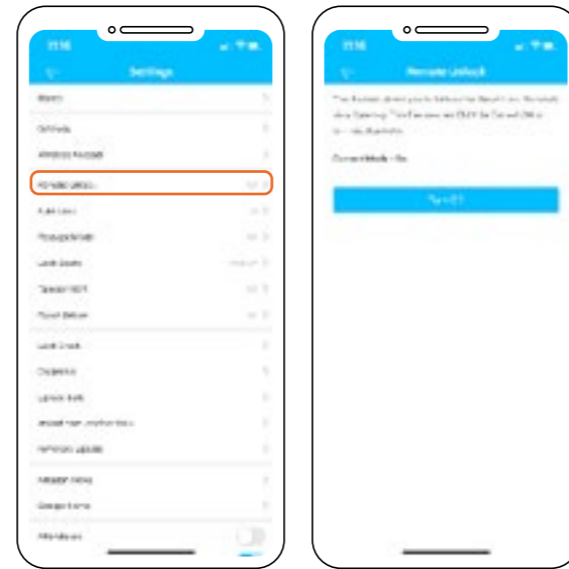

12. On the settings page select 'Turn on Remote Lock'.

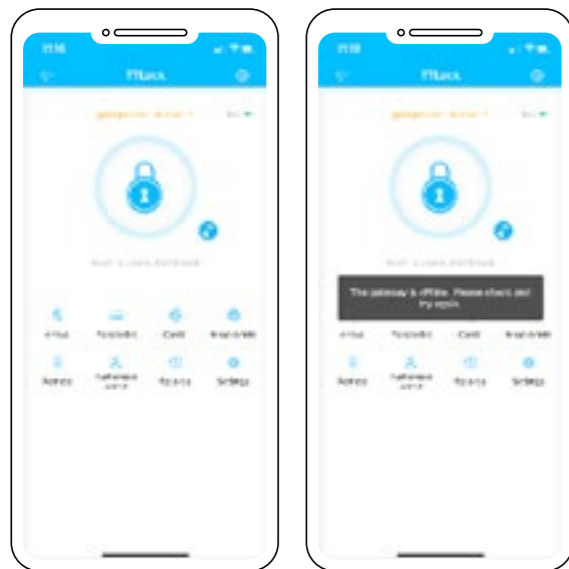

13. On the main programming screen of the lock a small Wi Fi symbol now appear next to the padlock symbol of the app.

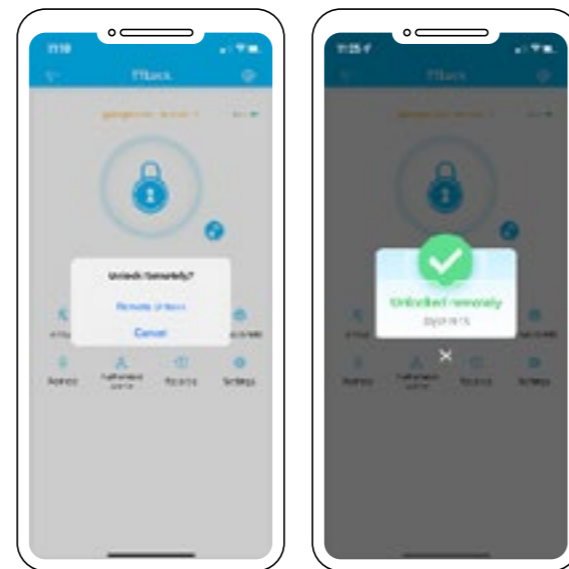

14. By clicking on the Wi Fi symbol, then clicking Remote unlock you will then be able to remotely unlock your lock from anywhere using the secure Wi Fi connection.

15. The app will show when the lock has been successfully unlocked.



PRODUCT WARRANTY

Customer Name: _____

Customer Phone: _____

Purchase Date: _____

Store name: _____

Receipt #: _____

Product Name: _____

Product Model: _____

Note: _____

Note:

1. Please keep this card so that you can use it when you need warranty service.
2. We provide you with a two-year warranty from the date of purchase.



127 Diana Drive
Glenfield
Auckland 0627
Ph: +64 9 444 5359
Email: sales@gdrutter.co.nz
Web: www.sylvan.co.nz