

Parts of door lock:

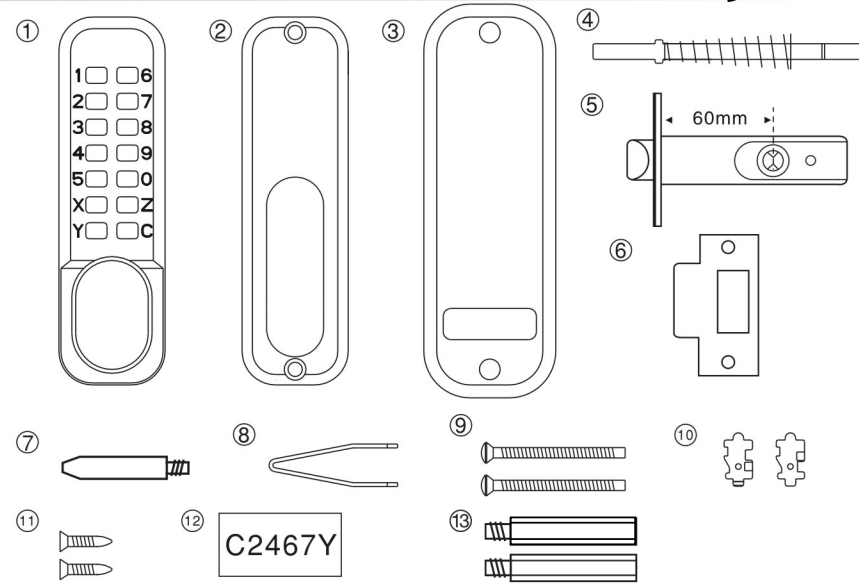

- | | |
|----------------------------|--|
| 1–Lock Password Box | 7–Latch support post |
| 2–Interior Panel | 8–Password Setting Forceps |
| 3–Rubber Cushion | 9–Fixing Bolts (length is adjustable) |
| 4–Lock Shaft (with spring) | 10–Backup Connection Pin |
| 5–Latch (60mm backsey) | 11–Fixing Wooden Bolt (for fixing lock beam) |
| 6–Strike plate | 12–Password Card |
| | 13–Lock body post |

Work Direction of Door:

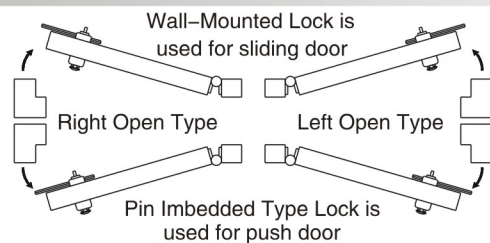

Door is open from right hand side, viewing from the inside part of door, the hinge is at the right side.

The installation direction of parts can be changed if necessary,

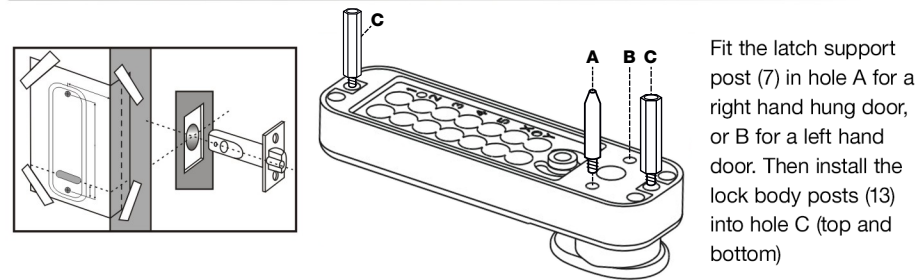

Fit the latch support post (7) in hole A for a right hand hung door, or B for a left hand door. Then install the lock body posts (13) into hole C (top and bottom)

- Tape the template to the door. Make sure that you fold it along the appropriate line, depending on the backset of the latch (60mm Or 70mm).
- Mark and drill all six 10mm holes.
- Use a chisel to clear the line of 4 × 10mm holes into a single slot.

POSITIONING AND FIXING THE LATCH

- Mark a central point on the 'centre line of latch' on the door edge.
- Drill a 25mm hole × 85mm deep.
- Insert the latch into the hole, and draw around the face plate.
- Remove the latch and cut a 3mm rebate so that the face plate will fit flush with the door.
- Secure the latch with the wood screws.
- When fitting a backplate to a left-hand door the BLUE screw must go in the right-hand hole and vice versa.

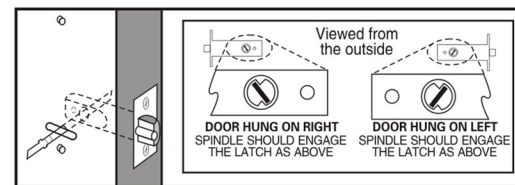

- Select the spindle to suit the thickness of the door.
- Insert the spindle through the slot in the door and make sure that it engages the latch correctly for the hand of the door – (see inset diagram.)

Installation:

Cut the lock shaft and adjust the length of the lock shaft for assuring to completely turn the screw into the password box if necessary according to the thickness of door.
The suitable thickness of door ranges 35mm–55mm according to the square sheet with spring.

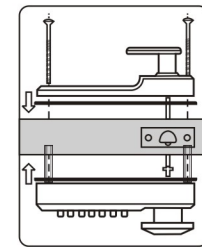

- Cut the fixing bolts to suit the door thickness, allowing at least one threaded section to screw into the lockcase.
- Hold the lock case and the backplate, with the seals, onto the door with the spindle in position.
- Using the fixing bolts screw everything together through the top and bottom holes of the backplate. Before final tightening make sure the lock is vertical, and test the mechanism to ensure that it is all moving easily.

DO NOT CLOSE THE DOOR UNTIL YOU ARE SURE THAT THE CODE WORKS.

- DO NOT over tighten the fixing bolts as this may cause distortion and lead to poor operation.
- Position the strike plate on the door so that it lines up with the flat of the latchbolt, NOT THE PLUNGER.
- Mark the inner and outer edges of the strike plate and cut a 1mm rebate so that it fits flush with the surface of the door frame.
- Drill or cut a recess for the latchbolt.
- Fit the strike plate using only one wood screw as first to ensure that it is positioned accurately. The latch bolt, and not the plunger, should enter the aperture easily, and be held without too much 'play'. When satisfied secure the strike with the second screw.

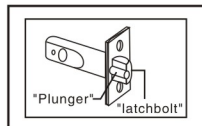

N.B. The plunger beside the latchbolt deadlocks the latchbolt and protects it against manipulation. IT MUST NOT enter the strike plate hole when the door is closed.

Align to centre of door end

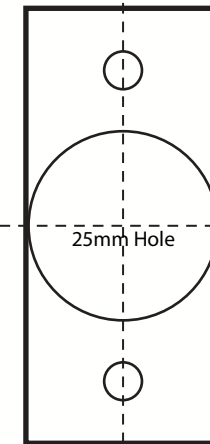

Centreline of latch

Fold along the edge of the door

Outline of rubber seal

60mm

130mm

Outline of lock case

8mm Hole

13mm Hole

8mm Hole

8mm Hole



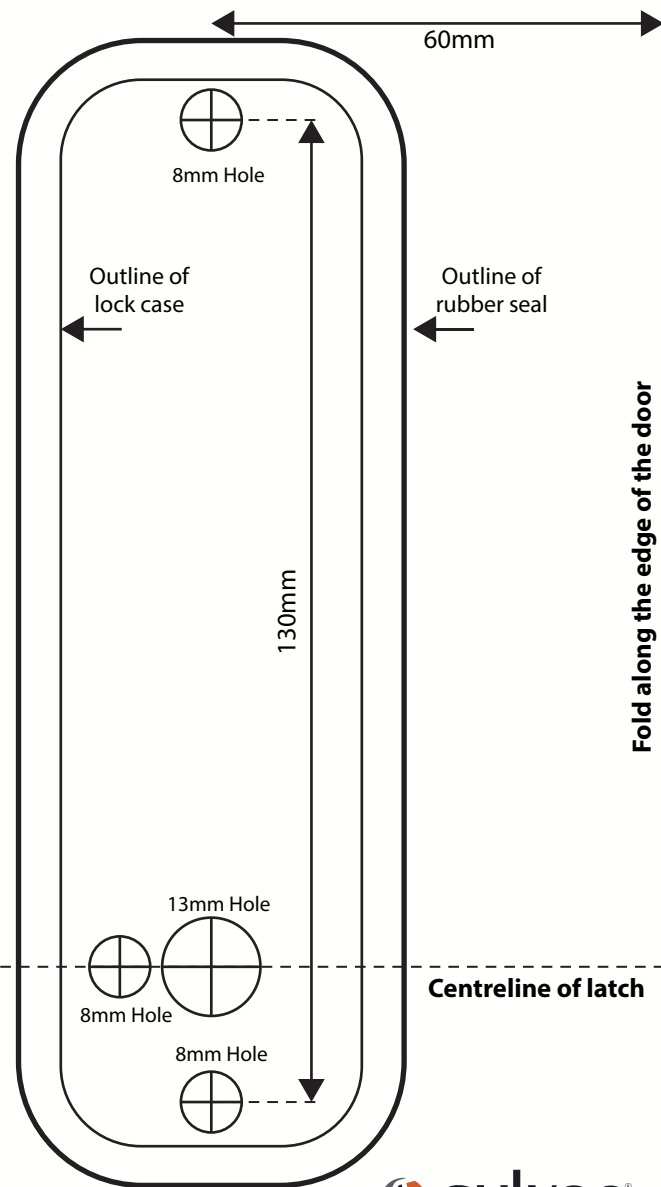

Fold along the edge of the door

Align to centre of door end

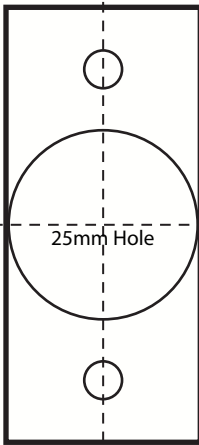

Modify password:

- 1: Remove the door lock box**
Loosen the two fixing screws, and then remove the door lock box
- 2: Press button C (IMPORTANT)**
- 3: Remove the rear panel**
Turn over the door lock box, loosen the screws and then remove the rear panel.

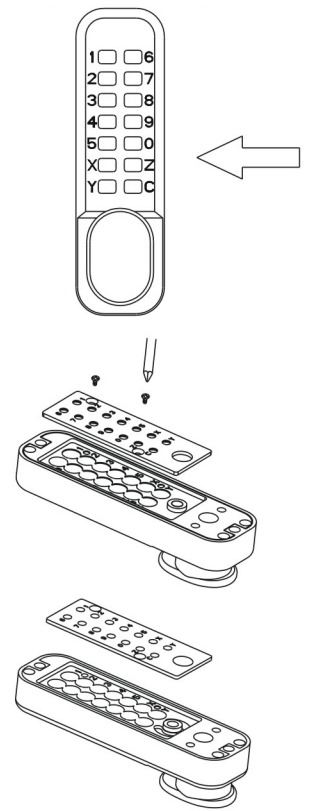

- 4: Expose the top of the connection pin, one is light color (corresponding connection pin of button C), and others are red or blue.**

Important Cautions:

Press in button C when removing or assembling connection pin. The password lock may possibly be seriously damaged if above instruction is neglected.

Button C

Modify password:

- 5: Cancel all password settings**
Remove all red and blue connection pins with small tweezers.
- Caution: Do not remove the light colored connection pin of button C.

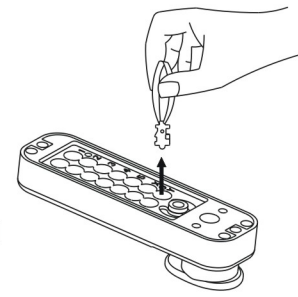

- 6: Set new password**
After selecting the numbers or letters for the password, connect the red connection pin with the corresponding holes of the password. Pay attention to the direction of connection pin.

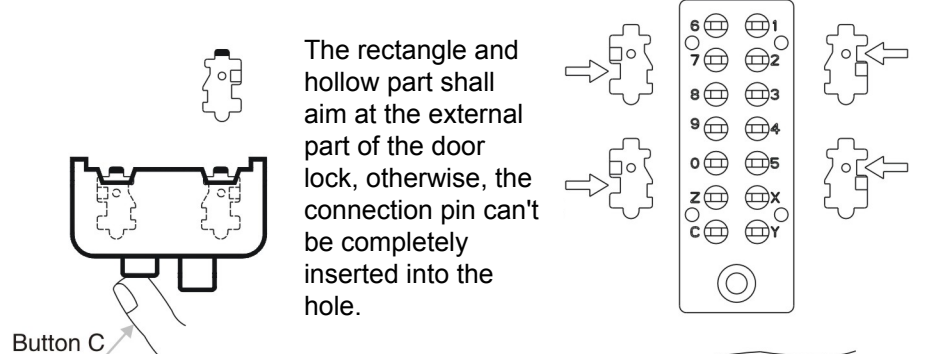

Insert all blue connection pins into the rest holes.

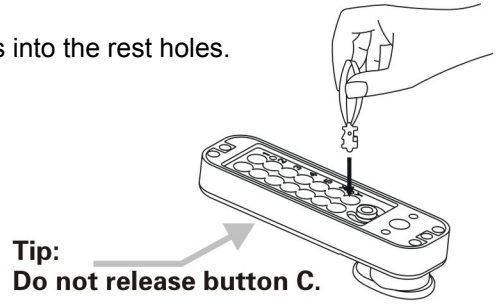

Modify password:

- 7 Assemble the door lock and check if the door lock works normally**
Check all springs, then install the rear panel and tighten the screws.
- 8 Hold button C before install the lock in the door, and then check if the password works normally.**

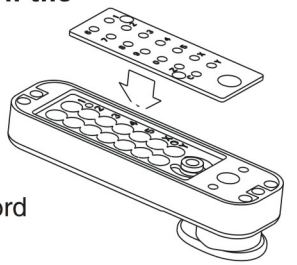

Confirm the work direction of the door (Please refer to "Installation Instructions")

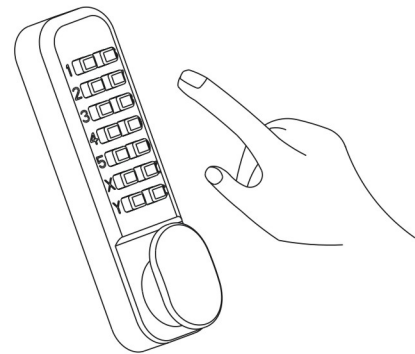

And check if the door handle works normally.

- 9 Install the lock in the door**
Install the lock in the door with two bolts, assure the lock shaft keep at correct direction (Please refer to "Installation Instructions")

Before close the door,
Hold button C and check if the password works normally, then check if the door handle and lock works normally.

