

## LEVERSET INSTALLATION INSTRUCTIONS AND TEMPLATE

### BEFORE PROCEEDING:

1. Read the installation instructions prior to installing the leverset.
2. Confirm that the backset of the leverset is the same as the door backset.  
If not adjust the latch backset as shown in step 1.

### TOOLS REQUIRED:

- For wooden door preparation:
- Electric drill
  - 54mm and 25mm diameter wood drill
  - 25mm chisel

- For leverset installation:
- Philips screwdriver
  - Soft faced hammer

### 1. ADJUSTABLE LATCH FOR 60mm & 70mm BACKSET

Adjustable latch was preset at factory for a 70mm backset. If a 60mm backset is required please adjust as shown below.

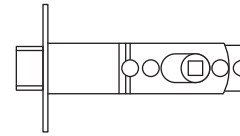
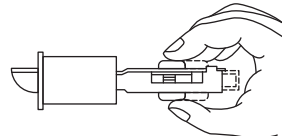
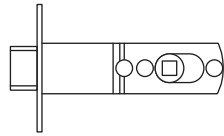
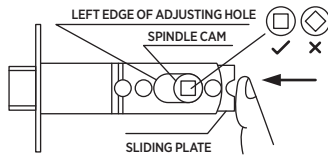

- To adjust to 60mm backset push the spindle plate or slide the spindle cam or sliding plate all the way to the left.
- Align the spindle cam square hole to the correct orientation, so that the spindle plate can slide easily.
- Ensure that the stem holes are properly aligned and clear.
- Latch is now set to 60mm backset.
- To re-set to 70mm backset, pull the spindle cam to the right all the way.
- Ensure that the stem holes are clear.
- Latch set to 70mm backset.

### 3. DOOR PREPARATION

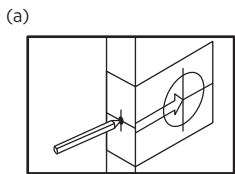

- Position the horizontal center line of the template at the height of 914mm or 965mm from the finished floor, fold template on the corner of the door and mark the center of the hole on the door edge.
- Select 60mm or 70mm backset as desired and mark center of the hole on the face of the door.

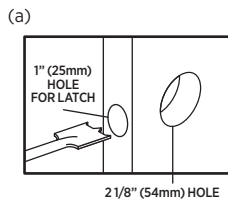

- Using a hole saw, drill a 54mm hole through the door. Drilling from both sides for a cleaner finish.
- Drill squarely to the door edge 25mm diameter hole for mortise type latch (ensure that the hole center is at the 1/2 of the door thickness point).

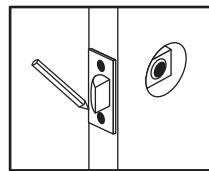

- Insert latch in hole and position face plate vertically on door edge. Mark outline of face plate and remove latch.

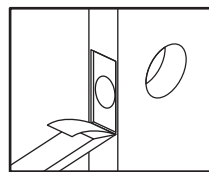

- Chisel 3mm deep or until face plate is flush with door edge.

### 4. LATCH INSTALLATION

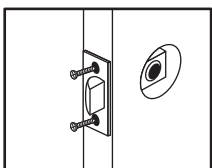

Insert Latch and Tighten 2x supplied wood screws

## 5. FRAME PREPARATION

(A)

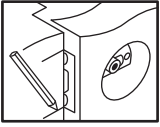

- Close door until latch touches jamb to locate strike on jamb and center line of strike.
- Open door and extend line from mark to frame jamb.
- Measure 1/2 of door thickness from door jamb and mark vertical center line for strike. Measure mid point and mark drill point center for strike along vertical center line.

(B)

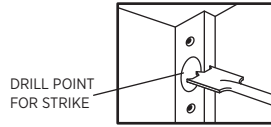

- Drill 25mm hole 13mm deep in door jamb at drill point
- CAUTION:** To assure proper lockset function, hole in jamb must be drilled a full 13mm deep.

(C)

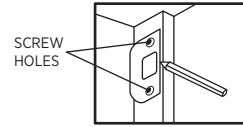

- Locate the strike cutout centrally over the 25mm hole on frame jamb.
- Mark outline of strike on frame jamb and chisel 1.6mm deep for strike.
- Install plastic strike box before installing striker plate.

## 6. INSTALL STRIKE

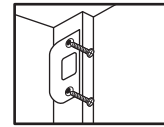

- Install strike and tighten 2x supplied wood screws
- Adjustable tang on strike permits bending in or out to eliminate gaps between door and door stop.
- Verify that latch bolt fits properly into the strike opening before tightening the screws.

## 7. INSTALL LEVER

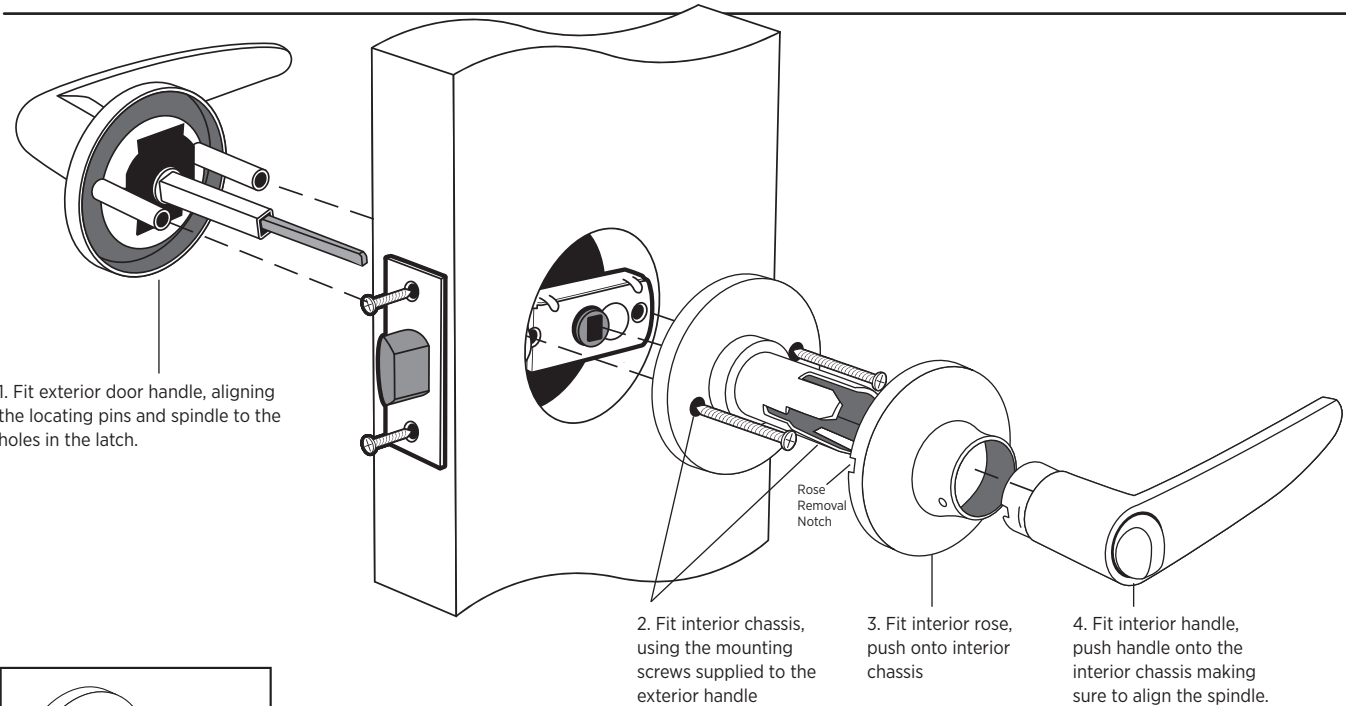

- Fit exterior door handle, aligning the locating pins and spindle to the holes in the latch.

- Fit interior chassis, using the mounting screws supplied to the exterior handle

- Fit interior rose, push onto interior chassis

- Fit interior handle, push handle onto the interior chassis making sure to align the spindle.

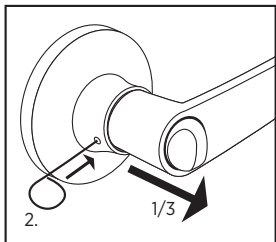

### To remove the internal handle:

- 1) Pull handle with force and locate the silver release pin
- 2) Using the supplied tool, push release pin in and while depressed (3), pull handle off the chassis firmly.

To reinstall, make sure to push release pin in to allow the handle to move down the shaft.

## 8. DRILLING TEMPLATE

Drill 25mm hole at center of door edge

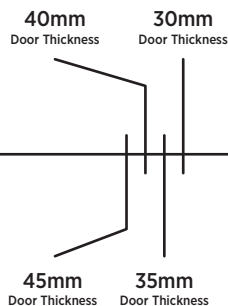

Fold on dotted line and fit to door edge

For Backset 70mm

For Backset 60mm

Fits 54mm Cylinder Hole

