

1 Mark and drill door

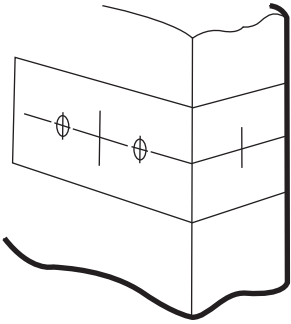

2 Check forend of latch and fit latch

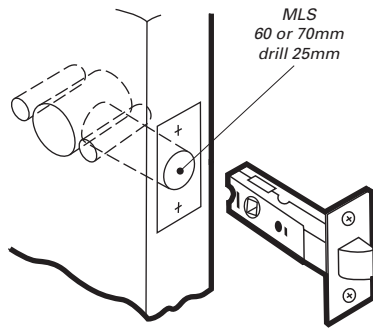

3 Fit spindle through latch

Grooved face downwards
Allow equal length of spindle on either side of door.

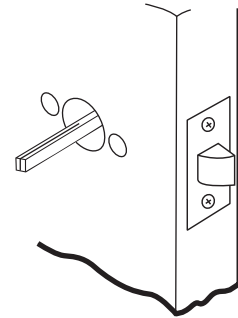

4 Drill and fit 1x wood screw for alignment only

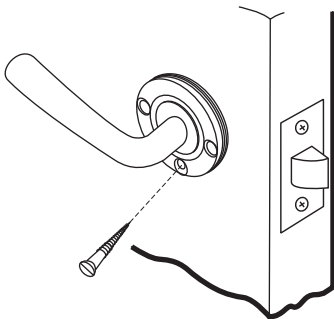

5 IMPORTANT STEP

Fit through bolt fixing screws.

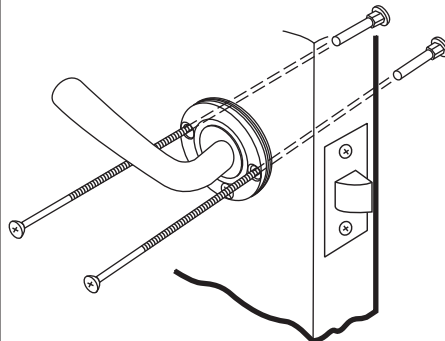

6 Fit cover plates over handles, ensure notch is at the bottom

Tighten up grub screws onto the spindle using allen key provided.

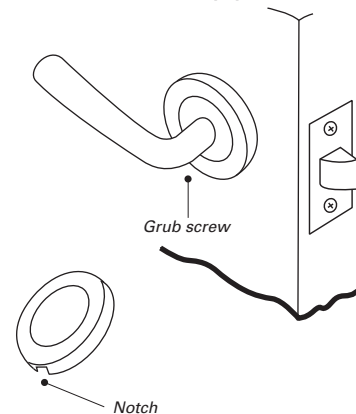

Square door edge Bevel door edge

Place template on high edge of bevel door

Mark centre of door

Drill 25mm hole at centre of the door edge

For 60mm backset fold here

